

Heavy duty access covers require the installation of an independently supported cover slab (see note 4)

NOTES:

1. Access covers are the responsibility of the client unless stated at time of tender.
2. The tank diameter is the nominal internal diameter, the civil engineer should allow 50mm all round to allow for joints, wall thicknesses and stiffening ribs
3. All civil engineering to be executed by others including fixing of any non-standard or heavy duty access cover.
4. The grp tank is not a load bearing member. Any non-standard or heavy duty manhole cover must be supported on a separate isolated roof slab.
5. Cable duct and sewer inlets may be positioned around the tank to suit clients reasonable requirements. Where the required position coincides with structural detail it will be placed in the nearest lower and/or highest adjacent position.
6. Reinforcing bars in concrete to be kept at least 75mm away from access opening in the vicinity of the top guide-rail bracket fixing holes.

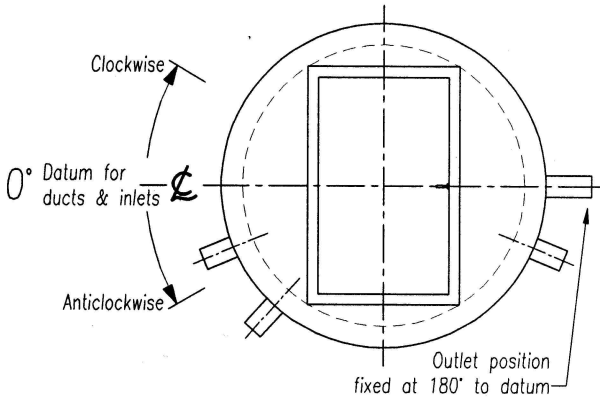

Please indicate nominal internal sump dia.						
1000	1250	1500	1800	2500	3000	4000

Item	Dim.	Invert depth mm	Stub pipe diameter	Degrees from datum	
				Clockwise	Anticlockwise
Well depth	A		N/A	N/A	N/A
Inlets	B1				
	B2				
	B3				
	B4				
	B5				
Cable Duct	C		100nb Minimum		
Outlet	D			Fixed at 180° (see plan)	
Vent	E				

Tank manufactured to tolerance of ±10mm on all dimensions

W.O. Ref.	
Manhole rating, please indicate with a tick	Pedestrian rating 1 tonne Heavy duty rating Facta Class AA Facta Class AAA Facta Class B BS-EN 124-D400

